

# FALL PROTECTION SOLUTIONS

**RIGID**   
**LIFELINES**  
Promise to Perform Industries, Inc.



**PERMANENT | MOBILE | CUSTOM**

# FALL PROTECTION SOLUTIONS



## RIGID LIFELINES®

### Rigid Rail Leaders ..... 3

#### Our Products

#### Tracks for Fall Protection ..... 4

#### Anchor Trolley™ ..... 6

#### Permanent Anchor Track™ Systems..... 8

#### Mobile Anchor Track™ Systems ..... 20

#### Custom Fall Protection Systems..... 24

#### System Accessories ..... 25

### Why Rigid Lifelines? ..... 26

### Laws and Codes ..... 27

# RIGID RAIL LEADERS

For over 20 years, Rigid Lifelines® has been engineering, designing, and testing rigid rail fall protection systems. All of our rigid rail systems comply with OSHA 1910, OSHA 1926, and ANSI Z359 standards. By meeting OSHA and ANSI regulations, our rigid rail systems reduce workplace risks and protect your workers from hazards. Our knowledge of fall protection codes allows our engineers to stay current while pursuing new, safer solutions for working at height. By serving on the ANSI Fall Protection Code committee and several ANSI sub-committees, our engineers work closely with building architects, engineers, and safety personnel to assist you in any way we can.

Our fully customized solutions have driven the development of our rigid rail systems, as unique challenges require us to deliver innovative approaches. In fact, these new solutions are incorporated into our standardized product line, readily available if similar applications arise. In addition, our bi-coastal manufacturing allows us to serve customers on the East and West Coasts and everywhere in between. Our large manufacturing facilities provide enough space to manufacture systems quickly and to stock a large quantity of replacement parts available for fast shipping.

Our quality control and manufacturing protocols guarantee that we provide exceptional systems. We are an ISO 9001:2015 registered company, meaning our systems fulfill international criteria for quality and safety. Our quality management and inspectors thoroughly examine each system throughout the manufacturing process to ensure system quality. Our certified welding also assures the quality of our rigid rail systems. All of our welders have their performance certified by the American Welding Society (AWS) in either Steel D1.1 or Aluminum D1.2.

We offer permanent or mobile Anchor Track™ Systems, including the mobile Griffin® and permanent Traveling Bridge. All of our Anchor Track Systems feature our enclosed Anchor Track and Anchor Trolley technology. Our Anchor Track eliminates the bounce effect and reduces the potential for secondary fall injuries. Our Anchor Trolley offers effortless movement, minimizes post-fall drift, and increases self-rescue ability. The zero-deflection of our rigid Anchor Track Systems means that our fall distances and deceleration forces are a fraction of those experienced by users of overhead cable systems.

All of our Anchor Track Systems and components as well as some wearable parts, such as Anchor Trolley wheels and teeth, come with a 10-year warranty coverage. For a full Warranty and Service Policy, email us at [sales@Spanco.com](mailto:sales@Spanco.com).

We hope that you find everything you need to keep your workers more secure while working at height. If you can't find what you're looking for, let us know. You can send us an email at [sales@Spanco.com](mailto:sales@Spanco.com) or give us a call at **800-869-2080**. One of our technical sales specialists will be happy to assist you.



# TRACKS FOR FALL PROTECTION

## High Performance, Low Maintenance

**Rigid Lifelines® tracks** are self-cleaning, so trolleys continuously roll with minimal resistance. The enclosed track self-centers the trolleys, which protects trolley wheels and ensures their accurate alignment. Plus, our rigid track design saves up to three feet of headroom because—unlike wire rope systems—there is no need for a “sag allowance.”

### Plain Track: PT Series

- Our lowest profile design keeps installation space requirements to a minimum.
- Track can be custom-curved for specific paths.

### Trussed Track: R Series

- Trussed design spans greater distance between supports.
- Combination of high-strength to low-weight ratio reduces stress on structures.

### Dual Trussed Track: DST Series

- All the advantages of the trussed design, but dual tracks allow two or more users to pass each other in the same work area.

### Triple Trussed Track: TST Series

- All the advantages of the trussed design, but three workers can be connected and pass one another within the protected workspace.

### Quad Trussed Track: QST Series

- All the advantages of the trussed design, but four workers can be connected and pass one another within the protected workspace.

Plain Track  
PT Series

*PT Series and R Series are available in stainless steel for 500-Series track.*

Trussed Track  
R Series

Dual Trussed Track  
DST Series

Triple Trussed Track  
TST Series

Quad Trussed Track  
QST Series

## Track Hardware

### Plain Track Flush Mount

Mount either parallel or perpendicular to ceiling beams.

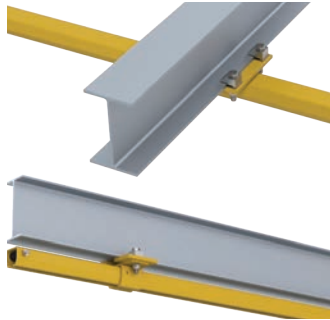

**Sloped Hangers** with drop rods accommodate slopes up to 14 degrees. Call for system applicability. Sway bracing is required.



### Plain Track Drop Rod Hanger Assembly

Features support bracket, 12-inch drop rod, and adjustable roof beam clamp. Sway bracing is required.



### End Stop Bumper

Standard on all systems. Bumper is through-bolted to track ends; resilient rubber increases impact resistance.

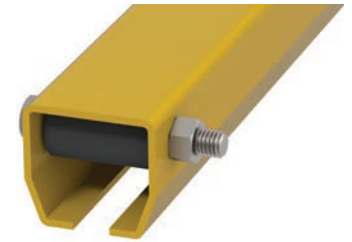

### Trussed Track Flush-Cross Mount

Customers can hang a truss track perpendicular to their existing structural beam.



### Plain Track Splice

Precisely align and connect track sections using two vertical and four horizontal adjustment screws (provided).

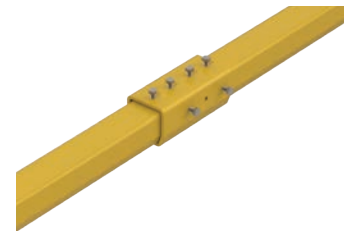

### Trussed Track Drop Rod Hanger Assembly

Features support bracket, 12-inch drop rod, and adjustable roof beam clamp. Sway bracing is required.



### Trussed Track Splice

This two-piece splice features the same splice as above. The second piece is a plate for truss. Hardware is provided.



### Low Headroom Truss Hanger Assembly

In some applications, the truss can be mounted through the web, which saves headroom. This hanger type is also referred to as a through-web hanger.



## Track Options

- **Steel track:** rolled from ASTM A572, A607, or A715 grade steel; available with enamel, ArmorPoxy, Macropoxy, or galvanized coatings
- **Stainless steel track:** 304 stainless for 500-Series track
- **Mylar™ lip seal:** for additional track protection from very heavy dust or paint overspray applications

# ANCHOR TROLLEY

## Minimizing Track Drift

**The Anchor Trolley** is our patented\* innovation in rolling trolley technology. The Anchor Trolley is designed with cone teeth made of hardened alloy steel that act as a braking mechanism and engage the steel track in the event of a fall. The engagement of the trolley teeth and track causes the trolley to anchor into place without damaging the track, virtually eliminating post-fall drift on the track. The Anchor Trolley greatly increases the opportunity for conscious and able-bodied workers to perform a self-rescue after a fall event. Like our other trolleys, the Anchor Trolley is made from non-consumable materials while being weather-proof and temperature-proof. This design ensures that you still have the same smooth movement that has come to be associated with Rigid Lifelines® enclosed track fall arrest trolleys.

### Features

- Reduces drifting on the track after a fall event
- Increases the chances for self-rescue
- Standard with Rigid Lifelines Anchor Track Systems

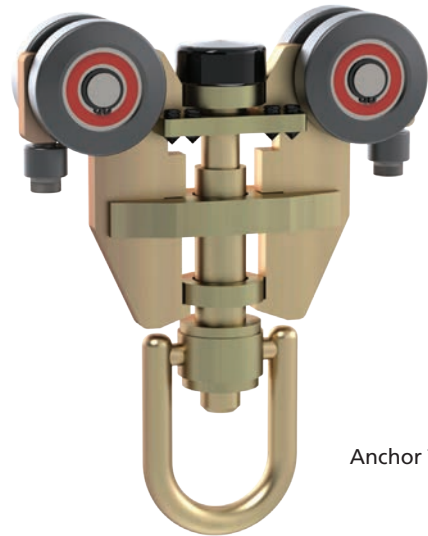

Anchor Trolley



The Anchor Trolley travels inside the Rigid Lifelines track.

\*US Patent. No. 8,978,821; 9,901,759; 10,617,897

## Greatly Reduces Risk of Suspension Trauma





### Highly Responsive Trolleys

For fall arrest systems, how the trolley rolls is the difference between user frustration and enthusiastic user acceptance. Our multipronged approach to minimum rolling resistance includes the following:

- Enclosed tracks, protecting trolley wheels and their alignment
- Self-cleaning tracks
- Sealed bearings for trolley wheels

Rigid Lifelines trolleys readily and effortlessly follow their user. They're also very responsive. After the user stops moving, the self-retracting lanyard brings the trolley as close as possible to the worker.

### Swiveling Connector Eliminates Side-Loading Stress

On many of our Anchor Track Systems, users are free to travel up to 30 degrees off-plumb of the track. On competing systems, that sort of travel would cause side-loading stress to the trolley's swiveling connector.

By comparison, the swiveling connector on our Anchor Trolley rotates 360 degrees preventing the lanyard's strap from getting twisted. The swiveling connector also swivels 180 degrees off-plumb to minimize side-loading stresses. These swiveling and pivoting actions are virtually imperceptible to the user. Together, they provide maximum freedom of movement and minimal equipment wear.

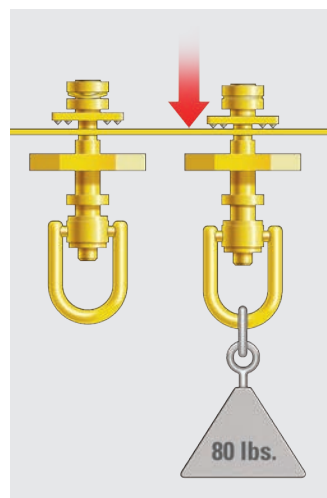

# CEILING-MOUNTED MONORAIL

## Fall Protection without Loss of Floor Space

**Rigid Lifelines Ceiling-Mounted Monorail Anchor Track Systems** easily mount to existing structures and can support long runs and curves.

Users travel the track's fixed path, but with the ability to move up to 30 degrees off-plumb—all while benefiting from rigid track protection (minimal fall distance). This system is widely used for protected worker mobility for vehicle loading/unloading, industrial cleaning, and maintenance tasks.

Our monorail system can be readily installed in buildings with very tall ceilings. It is available:

- As hanger kit only
- As a complete system kit
- As a custom-engineered system to meet your specific needs

### Application Options

- Single, dual, or multiple tracks for use by one, two, or multiple workers
- Tracks can be mounted to a sloped beam up to 14 degrees using sloped hangers with drop rods
- Many hanger options including flush mount, bar joist, and wood joist connections
- 2-way or 3-way switches allow multiple users to move in different directions on the same track
- Stainless steel track construction
- Curved tracks

### Design

Track(s) attaches to existing structures.





## Support Structures

Tracks are mounted either:

- Flush-cross mounted to ceiling beams
- Flush-parallel mounted to the ceiling beams
- Mounted with any length drop rods (requires sway bracing), including hangers for slopes up to 14 degrees

## Advantages

- Requires no floor space for support columns
- Easy installation, even in large buildings with tall ceilings
- Layout flexibility, including curves, slopes, switches, multiple tracks, etc.
- Ideal for repeated travel along fixed pathways

## Examples

- Truck, Rail, Air, and Transit Facilities
- Petroleum and Coal Processing Plants
- Chemical, Plastics, and Rubber Processing Facilities
- Pulp and Paper Manufacturing
- Machinery Manufacturing
- Warehousing and Storage Facilities
- Performing Arts and Entertainment Industry

## Coverage Area

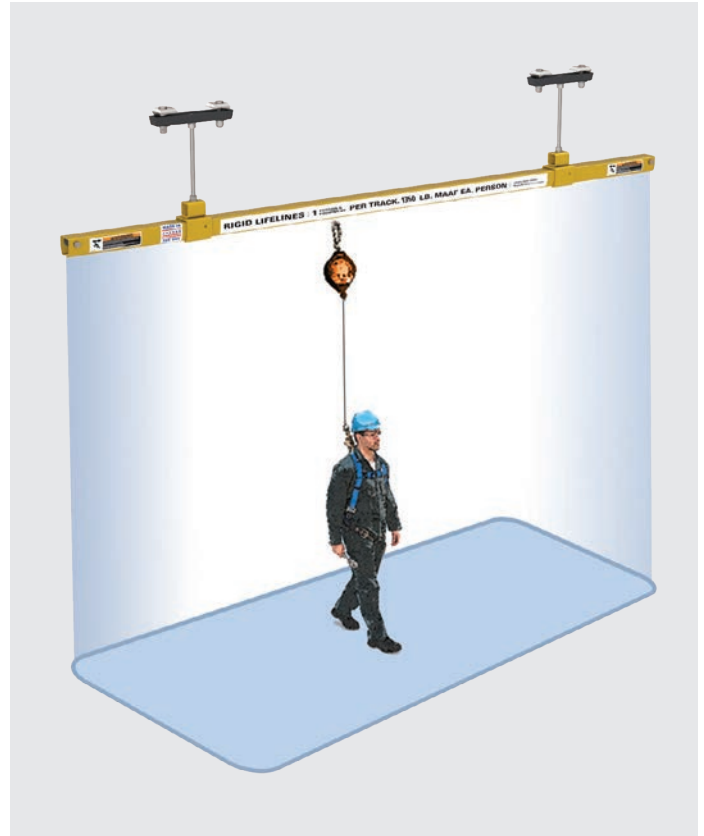

## Ceiling-Mounted Monorail Anchor Track System

Single and dual track options are available.

Drop-rod hangers require sway bracing.

# TRAVELING BRIDGE

## 360-Degree User Movement

**Rigid Lifelines Traveling Bridge Anchor Track System** features a trolley that traverses a traveling bridge. The traveling bridge, in turn, glides along two mounted runways.

With the double axes, the trolley can effortlessly follow the user in any direction (360 degrees). The worker's attachment point is always centered over the user's head—minimizing swing fall hazards—something not possible on wire rope or I-beam systems.

Ceiling-mounted systems are mounted either parallel or perpendicular (cross) to the building's existing ceiling support beams. Flush-mount hangers maximize working heights, while a drop-rod hanger with sway bracing can be used to overcome overhead obstacles.

Freestanding systems are compatible with large overhead cranes because they only come up to the length of the freestanding columns. Freestanding systems can also be easily repositioned when workflow or plant layout changes.

### Application Options

- Virtually unlimited runway lengths
- Standard bridge lengths up to 32 feet; custom bridge lengths up to 40 feet
- Multiple bridges for multiple workers and/or very large work areas
- Stainless steel construction
- Kit systems or custom-engineered systems
- Many hanger options including flush mount, bar joist, and wood joist connections

### Support Structures

Tracks are mounted to either:

- The ceiling's existing support beams
- Freestanding floor-bolted support columns with headers

### Design

Tracks attach to existing structures or to freestanding columns and headers, and the bridge travels along the tracks.

### Advantages

- User's attachment is always centered over worker's head, minimizing swing fall hazards.
- System provides omni-directional, 360-degree user movement and protection.
- User can do multiple tasks over a large area without unhooking.
- Multiple bridges allow multiple users to work independently in separate areas while attached (up to two workers per bridge).

### Examples

- Aircraft Hangars and Factories
- Large Vehicle Maintenance Facilities

### Coverage Area

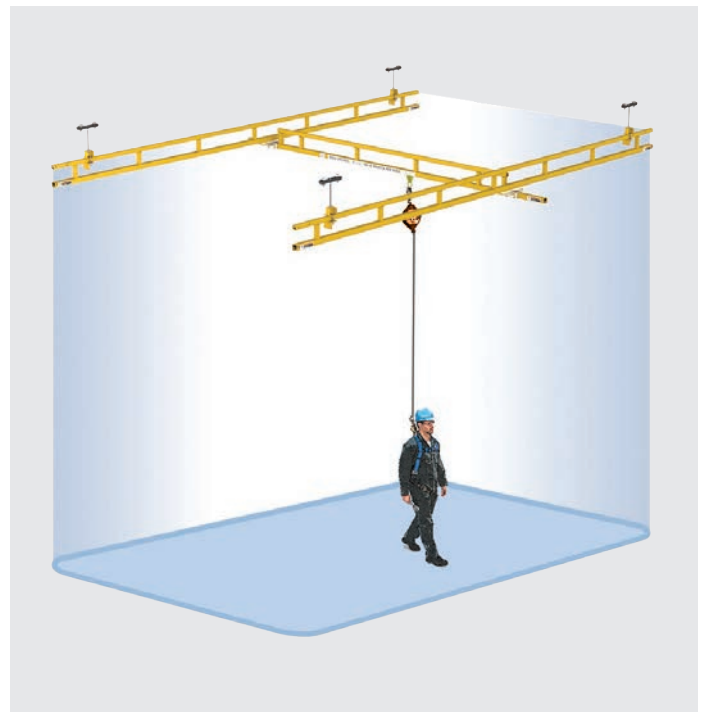

# Traveling Bridge Fall Protection System



Drop-rod hangers  
require sway bracing.



# FREESTANDING SYSTEMS

## For Long Outdoor Paths with No Existing Structures

**Rigid Lifelines Freestanding Anchor Track Systems** provide permanently installed fall protection over long spans where there are no existing structures.

### Inverted-L Anchor Track System

Wide flange steel columns with gusset reinforcements hold cantilevered headers from which the track(s) hangs. Each frame consists of a freestanding column topped with a header that forms the **L**.

- With 3 or more frames, track lengths are nearly limitless.
- Trolley-hook height starting at 22 feet allows access to the tops of railroad cars, tankers, trailers, outdoor equipment, and systems.
- Standard arm reach begins at 8 feet.
- Concrete foundations are required.



### Inverted-U Anchor Track System

Steel columns hold I-beam headers from which the track(s) hangs. Each frame consists of two freestanding columns topped with a header that forms the **U**.

- With 3 or more frames, track lengths are virtually unlimited.
- Heights and track lengths are available per application.
- May require concrete foundations, but are smaller than the foundations required by other cantilevered systems.



### T-Frame Anchor Track System

Steel columns hold I-beam headers from which the track(s) hangs. Each frame consists of a freestanding column topped with a header that forms the **T**.

- With 3 or more frames, the parallel tracks can be designed to span any length.
- Service two lines of vehicles with only one row of columns.
- Concrete foundations are required.



## Application Options

- Single, dual, or multiple tracks for use by one, two, or multiple workers
- Custom designs for your facility's unique demands; includes custom-sized cantilevers and/or support structures
- Curved track

## Design

Track(s) attaches to headers supported by freestanding columns.

## Support Structures

Three different designs, each with freestanding columns supporting header-attached trussed track(s).

## Advantages

Long spans of fall protection coverage in areas without existing structures.

## Examples

- Railcar Sidings
- Truck Loading, Securing, and Tarping
- Tank Car Loading and Servicing (e.g., water tankers)
- Agricultural Transportation

## Coverage Area



- Logging: Securing and Unloading
- Oil and Gas Extraction
- Petroleum and Coal Processing
- Manufacturing and Maintenance of Large Vehicles and Equipment



# FOLD-AWAY

## Compatible with Overhead Cranes and Space Restricted Work Areas

### Rigid Lifelines Fold-Away Anchor Track System

**System** is ideal for facilities needing a fall arrest system that folds up and out of the way.

When the arms are fully extended, the system provides workers with a fixed path of rigid track fall protection. Users can travel up to 30 degrees off-plumb of the track.

When not in use, the track and its arms can be folded against their support columns (e.g., the wall), leaving room for large overhead cranes. Locking mechanisms keep the system locked in place during use or storage.

Monorail track lengths of 40 feet or more allow multiple work areas covered by a single fall protection system.

### Application Options

- Single, dual, or multiple tracks for one, two, or multiple workers
- Larger systems using three or more arms typically have motorized rotation with electric motors
- Available as standard kit or custom engineered solution

### Design

Trussed track attaches to two or more arms that fold away when not in use.

### Support Structure

Arms attach to existing building columns or to freestanding columns.

### Advantages

- Folds out of the way for overhead cranes
- Ideal for narrow bays with inaccessible ceilings
- Excellent for space-restricted facilities
- Span multiple work areas with one system

### Examples

- Railroad and Truck Transportation Facilities
- Utilities
- Food Processing Facilities
- Petroleum and Coal Processing
- Plastics and Rubber Manufacturing
- Primary Metals Manufacturing

### Column-Mounted Fold-Away Anchor Track System



## Coverage Area

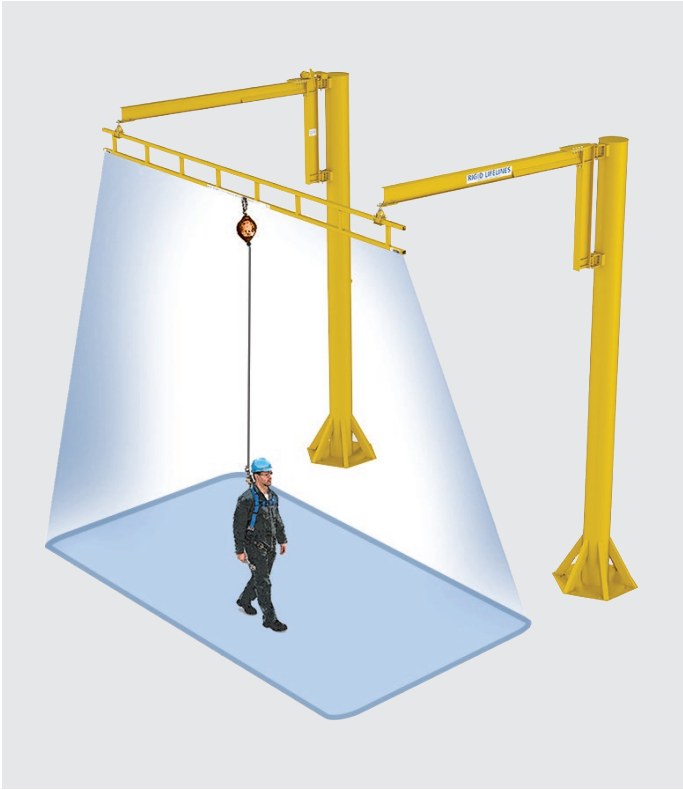

## Freestanding Fold-Away Anchor Track System

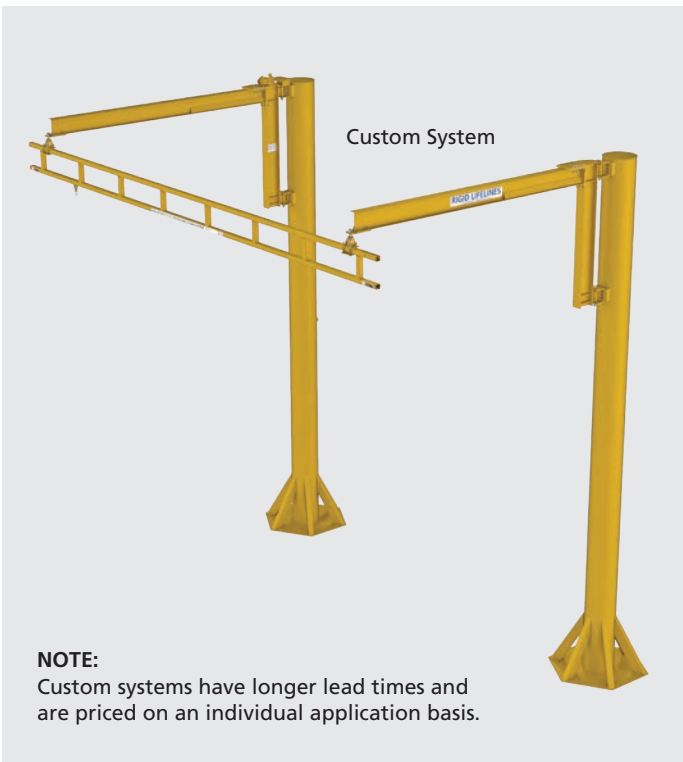

**NOTE:**  
Custom systems have longer lead times and are priced on an individual application basis.



# POST SUSPENSION

## Wide Coverage with Fewer Materials

**Rigid Lifelines Post Suspension Anchor Track System** designs deliver fall protection coverage to areas where conventional multiple columns cannot be installed due to obstacles or space restrictions.

Available as a single post, multiple post, or twin bay system (tracks on both sides of posts), our Post Suspension system can also be economical, requiring fewer foundations and 60-percent less steel than conventional designs.

### Single Post System

- Requires only one foundation
- Ideal for space-restricted or obstacle-filled areas
- Standard track lengths up to 53 feet
- Maximum trolley-hook height of 22 feet (custom heights available for multiple post and twin bay systems)

### Multiple Post System

- Requires fewer foundations than other designs
- Virtually unlimited track lengths starting at 23 feet
- Up to 100 feet between supports

### Application Options

- Can be engineered for single or twin bays (tracks on both sides of posts)
- Single, dual, or multiple tracks for one, two, or multiple workers

### Design

Track(s) attach to outrigger arms supported by tie rods and a mast.

### Support Structure

Freestanding mast(s) requiring one foundation per mast





### Advantages

Space-efficient and economical system

### Examples

- Railcar Sidings
- Truck Loading, Securing, and Tarping
- Tank Car Loading and Servicing
- Agricultural Transportation
- Logging: Securing and Unloading
- Oil and Gas Extraction
- Mining
- Food and Beverage Manufacturing

### Single Post Anchor Track System

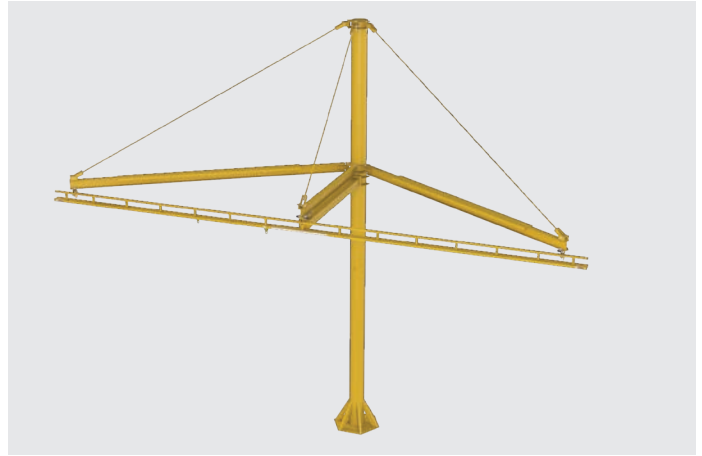

### Coverage Area

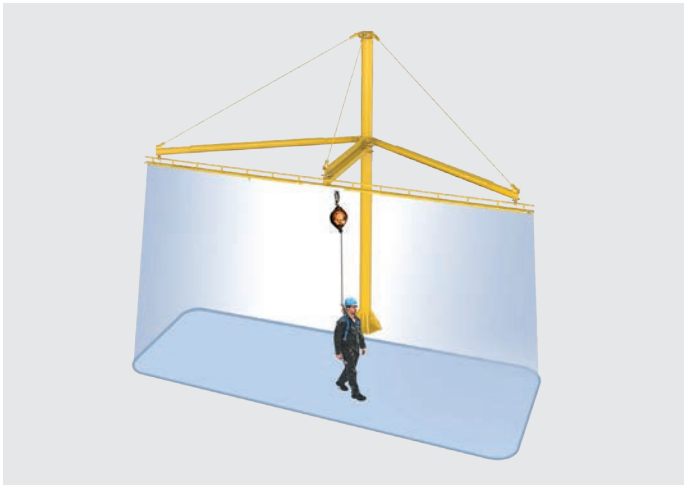

### Twin Bay Single Post Anchor Track System

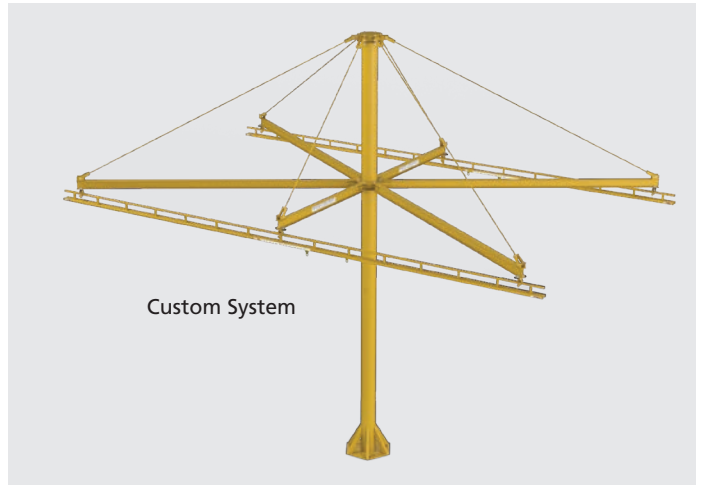

### Multiple Post Anchor Track System

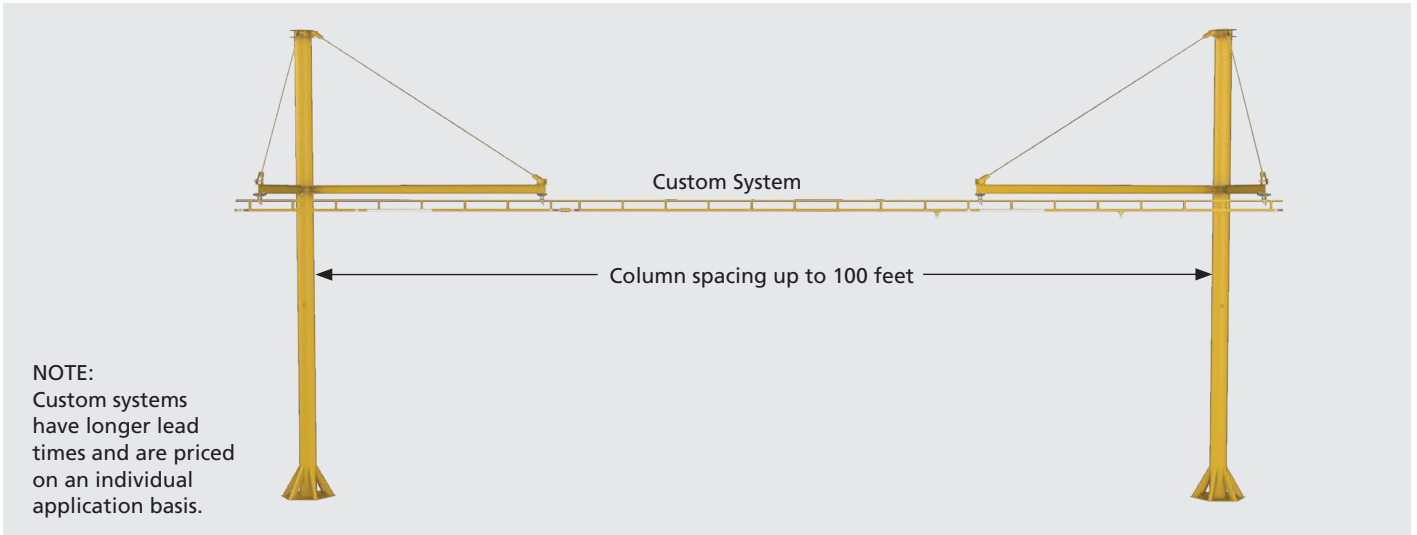

# SWING ARMS

## Compact System Minimizes Swing Fall Hazards



**Swing Arm Anchor Track Systems** provide a circular or semi-circular fall protection coverage area, making it ideal for small to medium-sized work areas.

Both the Swing Arm and its trolley follow the worker, keeping the trolley positioned directly above the user at all times—minimizing swing fall hazards.

When not in use, the Swing Arm can be swung back out of the way for overhead cranes. Standard fall protection spans range from 5 to 30 feet with 180-degree or 360-degree arm pivoting.

### Application Options

- Single, dual, or multiple tracks for one, two, or multiple workers (except for the two-person capacity Portable Base Swing Arm)
- Mobile design with counterweighted base is available
- Boom lock (required for Portable Base systems)

### Design

Track(s) attaches to a swing arm that pivots between 180 and 360 degrees.

### Support Structures

Swing Arm system is mounted to either:

- Existing wall columns
- Freestanding masts, either with a permanent base or a mobile, counterweighted base

### Advantages

- Minimizes swing fall hazards by constantly positioning trolley over user's head
- Swings out of the way of overhead cranes
- Excellent for small to medium-sized work areas

### Examples

- Utilities
- Water Transportation (e.g., water tankers)
- Food and Beverage Manufacturing
- Plastics and Rubber Manufacturing
- Primary Metals Manufacturing

## Coverage Area

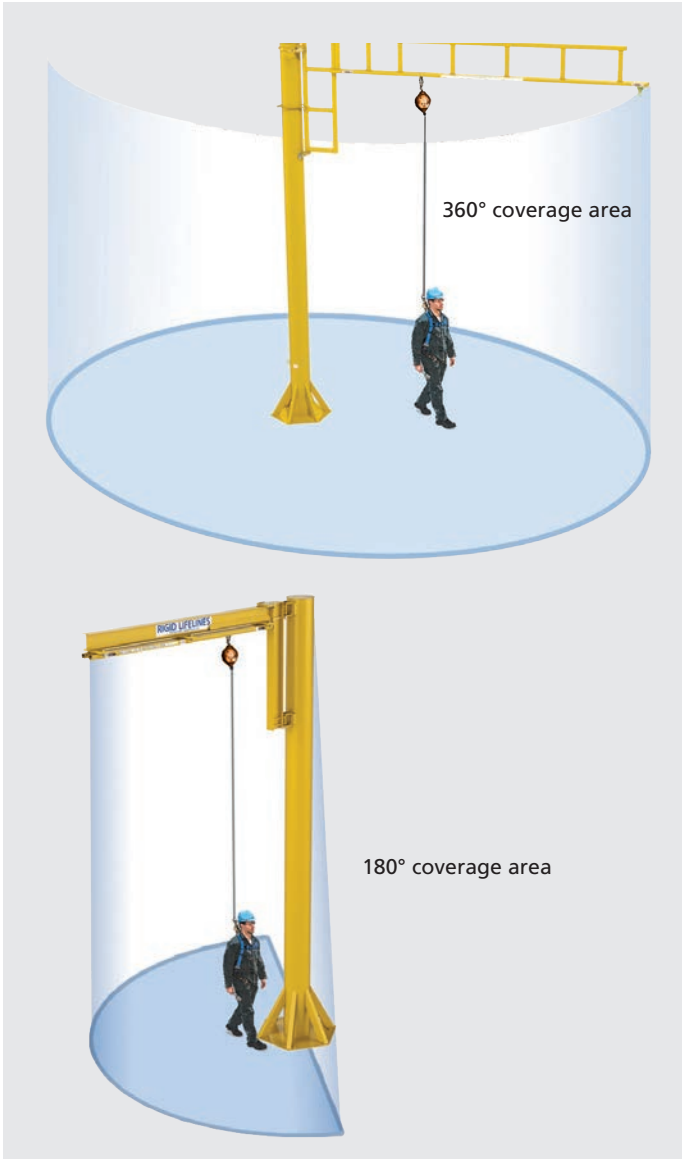

## Freestanding Swing Arm Anchor Track System

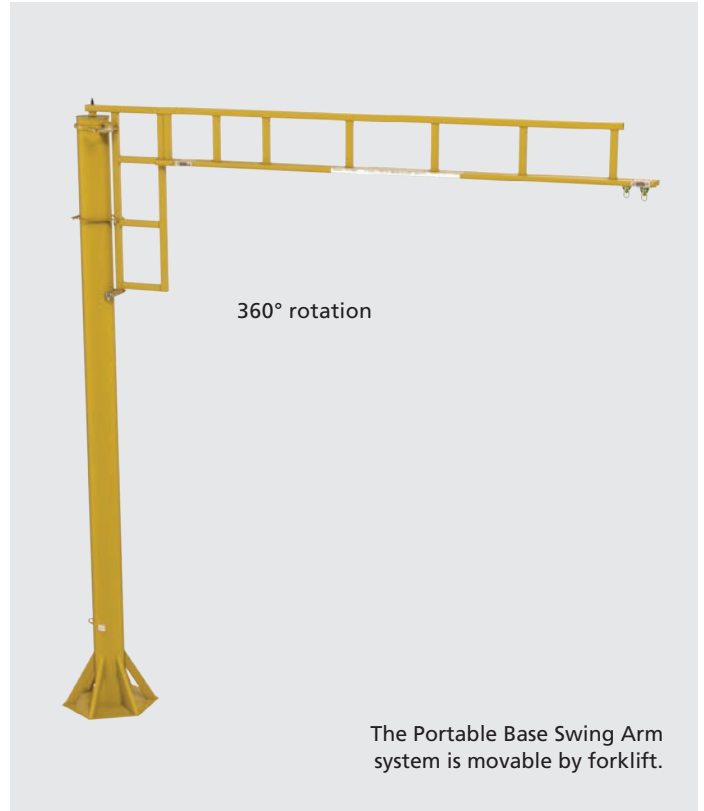

## Column-Mounted Swing Arm Anchor Track System

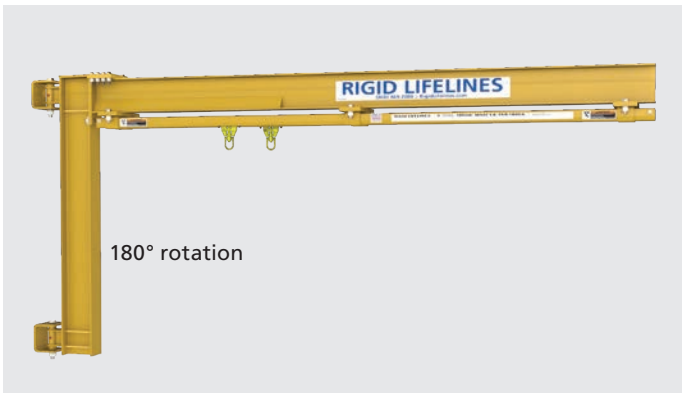

## Portable Base Swing Arm Anchor Track System

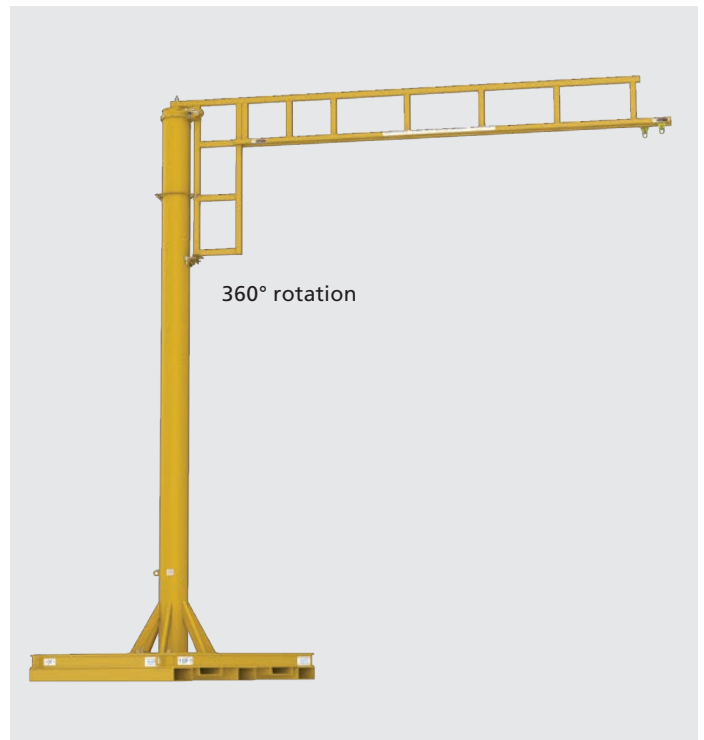

# ROLLING A-FRAME

## Fall Protection Anywhere

**Rigid Lifelines Rolling A-Frame Anchor Track System** is the ultimate in mobility for fall protection. Simply roll the system into position and lock into place.

Our Rolling A-Frame system can eliminate the need for a permanently installed system, while providing coverage to virtually every location in your plant. This mobile system is also available as a custom engineered solution for your facility.

### Application Options

- Single, dual, or multiple tracks for one, two, or multiple workers
- Manual leveling jacks
- Foam-filled pneumatic casters (tires)
- Nylacron™ casters
- Power drives

### Design

Track(s) attaches to a header supported by braces and legs equipped with casters.

### Support Structure

Caster-equipped legs and braces hold a header to which the track attaches.

### Fixed-Height Rolling A-Frame Anchor Track System



### Coverage Area



### Advantages

Highly mobile fall protection coverage

### Examples

- Aircraft Maintenance and Manufacturing
- Large Vehicle Maintenance and Manufacturing
- Oil and Gas Drilling and Extraction
- Mining and Excavating
- Utilities

### Adjustable-Height Rolling A-Frame Anchor Track System



# PORTABLE BOX FRAME

## Wide, Portable Coverage

**Rigid Lifelines Portable Box Frame Anchor Track System** provides fall protection coverage that other systems just can't achieve.

Available in a monorail or traveling bridge design, the Portable Box Frame offers customizable sizes and capacity ratings. By utilizing foam-filled pneumatic tires, four people can move this system manually.

### Application Options

- Single, dual, or multiple tracks for one, two, or multiple workers
- Traveling Bridge design

### Support Structures

Steel I-beam headers and braces attach to support legs equipped with wheels

### Advantages

- Highly portable fall protection coverage
- Large fall protection coverage area
- Able to be moved manually

#### NOTE:

Custom systems have longer lead times and are priced on an individual application basis.

### Coverage Area



### Examples

- Aircraft Maintenance and Manufacturing
- Large Vehicle Maintenance and Manufacturing
- Oil and Gas Drilling and Extraction
- Mining and Excavating
- Utilities

### Portable Box Frame Anchor Track System



### Portable Box Frame Anchor Track System with a Traveling Bridge



# GRIFFIN®

## Mobile Fall Protection for Many Locations

### Rigid Lifelines Griffin Anchor Track System

provides rigid track fall protection with coverage of up to 30 degrees off-plumb. With typical overall weights of approximately 15,000 pounds for the Skidded Griffin and 19,000 pounds for the Wheeled Griffin, the entire system can be moved in minutes using a large forklift for the Skidded system or a heavy-duty pickup truck for the Wheeled system.

Frequently used in exposed outdoor locations, our enclosed track design prevents dirt or ice build-up, so the trolley effortlessly follows users' movements as they traverse tops of vehicles and other large equipment.

- Standard track lengths from 20 to 60 feet
- Standard arm reach between 8 and 14 feet
- Trolley-hook height starting at 22 feet

Wheeled Griffin include the following:

- Hard rubber tires
- Steerable rolling chassis
- Drawbar Eye Coupler (for Pintle hitch)
- Bubble levels, leveling jacks, bottle jack, and bottle jack plate for system leveling

### Application Options

- Single, dual, or multiple tracks for use by one, two, or multiple workers
- Custom smaller sizes and configurations available
- Dual steer with two tow bars, one on each end of the system

### Design

Track(s) attaches to outrigger arms supported by tie rods, cross braces, masts, and counterweights.

### Support Structures

Track(s) is held by outrigger arms from two support columns attached to one of the following bases:

- Skid-mounted base
- Steerable wheeled chassis

### Advantages

- Excellent for temporary applications, indoors or outdoors
- Fully assembled system can be lifted with large forklift or, with the proper options, rolled or towed

### Examples

- Trucks: Loading, Securing, and Tarping
- Manufacturing and Maintenance of Large Vehicles and Equipment

### Coverage Area

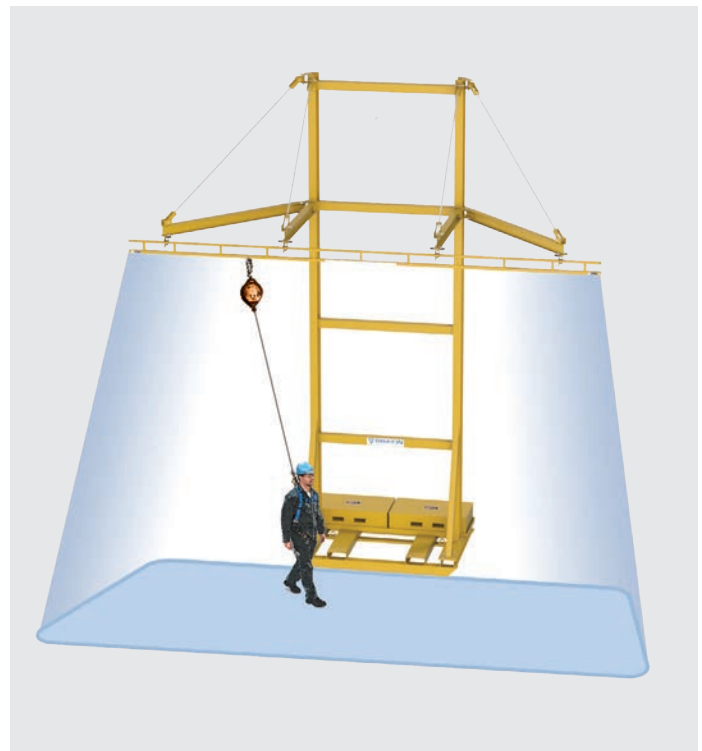

**Wheeled Griffin Anchor Track System**



**Skidded Griffin Anchor Track System**



# CUSTOM SYSTEMS

## One-of-a Kind Systems Welcomed

There's a simple way to test a manufacturer's willingness to do customized systems: How long do they take to return your calls?

At Rigid Lifelines, we are truly eager to design customized systems, and our fast response times prove it. We have a full, talented team of engineers that love a challenge. Plus, unique challenges force us to design innovative, ergonomic solutions that can be incorporated into our standardized systems.

Below is an example of one of the unique systems that our engineers have developed.

**NOTE:** Custom systems have longer lead times and are priced on an individual application basis.

### Ceiling-Mounted Traveling Bridge on Existing Overhead Crane Runways

A version of the Traveling Bridge can run on existing overhead crane runways. Typically under running, the end trucks are designed specifically to fit the existing runways. With the proper engineered controls and integration, this system can even be used with the overhead crane.

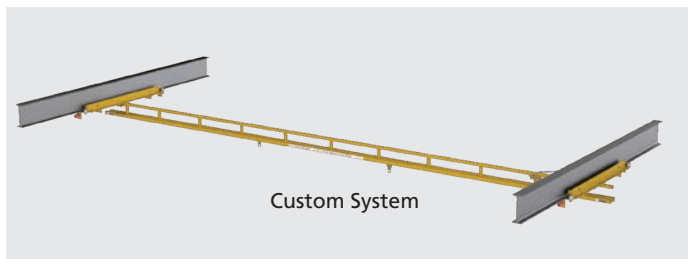

**NOTE:**

Side-mount trolleys are for use in fall restraint applications only when used in conjunction with a fixed-length lightweight lanyard that is equipped with energy absorbers. The side-mount trolley is not designed to support the weight of a self-retracting device (SRD or self-retracting lanyard (SRL).

## Custom Track Configurations

### Curved Track

At Rigid Lifelines, we understand that each application is unique and presents its own challenges. For this reason, all of our Anchor Track Systems can be completely customized.

Curved track is an example of a common customization. Available in plain or trussed track, our curved track comes standard at 45, 80, or 90-degree curves. However, our curved track can be curved to almost any required degree. Perfect for the transportation industry or for tight workspaces, curved track might be just what you need to maximize your specific workspace.

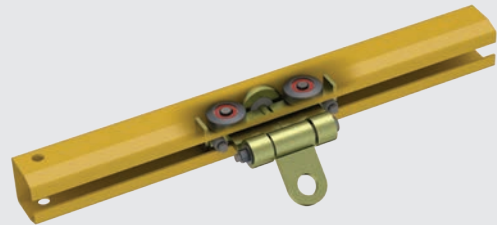

### Side-Mount Track

Does your application require fall restraint, but traditional guardrail systems get in the way of your workers? If so, our side-mount track might be the perfect fall restraint solution.

By using a special trolley, our side-mount track can keep workers from a leading edge or dangerous equipment. Our enclosed, rigid design ensures smooth trolley travel while keeping dust and debris out. Our side-mount track can be bolted, welded, or anchored to existing structures and can be designed for long spans or specific path designs, including curves or complete circles. Contact us today to see if our side-mount track is the right fall restraint system for your specific application.





### **C9000-G2, C9001-G2—Cable Hybrid Self-Retracting Lanyard, Class 1**

- Lengths: 20 feet (C9000-G2) and 30 feet (C9001-G2)
- Housing—high-impact resistant polymer
- Convenient carrying handle
- Cable material—galvanized alloy steel wire rope—3/16-inch diameter
- Working load capacity rating—310 pounds
- Minimum capacity rating—130 pounds
- Meets ANSI Z359.14-2021, ANSI A10-32-12
- Compliant with OSHA 1926 Subpart M, OSHA 1910
- Max arresting distance—24-inch
- Average arresting force—1,100 pounds
- Maximum arresting force—1,600 pounds



### **C7002-G2—Cable Self-Retracting Lanyard, Class 1**

- Lengths: 50 feet
- Housing—high-impact resistant polymer
- Convenient carrying handle
- Cable material—galvanized steel wire rope—3/16-inch diameter
- Working load capacity rating—310 pounds
- Minimum capacity rating—130 pounds
- Meets ANSI Z359.14-2021, ANSI A10-32-12
- Compliant with OSHA 1926 Subpart M, OSHA 1910
- Max arresting distance—24-inch
- Average arresting force—1,100 pounds
- Maximum arresting force—1,600 pounds



### **B2201, B2202 and B2203 Full-Body Harness**

- Sizes: S/M (B2201), L/XL (B2202), and XXL (B2203)
- Made up of high-tenacity polyester webbing—5,000-pound break strength
- One dorsal D-Ring for fall arrest
- Five-point adjustability (chest, legs, and torso)
- Grommeted waistband with tongue buckle adjustment
- Quick-connect chest and leg buckles for adjustability
- Two lanyard keepers for proper stowing of idle lanyard connector(s)
- Dual fall indicators on shoulder straps
- Meets ANSI Z359.11-2021, ANSI A10.32-12, OSHA 1910, and OSHA 1926 Subpart M
- Meets ANSI capacity range 130–310 pounds

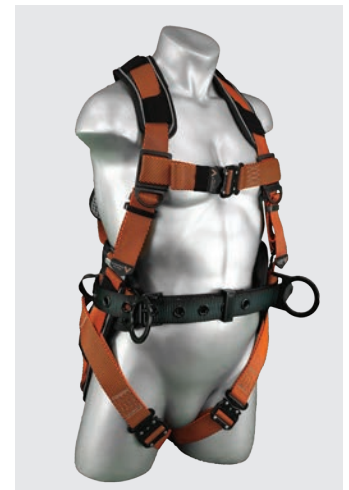

# WHY RIGID LIFELINES?

### Consistently Meeting Requirements

Our engineers have designed thousands of fall protection systems for clients across North America. People choose our fall protection systems because they meet or exceed OSHA and ANSI Z359 requirements while improving worker safety and productivity. No matter where you work or what task you may need to perform at height, we aim to provide a fall protection system that meets your needs.

### Bi-Coastal Manufacturing

We have manufacturing locations in Las Vegas, Nevada, and Morgantown, Pennsylvania. These two locations make it easier for us to serve customers everywhere between the East and West coasts.

### Experienced and Informed Team of Engineers

Our engineers serve on the ASSP/ANSI Z359 Fall Protection Code Writing Committee, ANSI sub-committees, and the Safety & Health Technology Committee of the Association for Iron & Steel Technology. By participating with these organizations, our engineers are able to keep a pulse on the latest changes in fall protection requirements and technology.

### Certified Manufacturing

Our welders are certified by the American Welding Society in steel (D1.1) and aluminum (D1.2) to ensure that every product we manufacture maintains quality. Our manufacturing engineers also ensure that ISO 9001:2015 procedures are adhered to as part of a quality management system for superior process improvement.



# LAWS AND CODES

## Fall Protection Standards (ANSI and OSHA)

**Fall protection regulations** make a distinction between whether you're in General Industry or the Construction Industry. This overview first discusses what is common to both industries.

The most important Fall Protection Code is ANSI Z359.2 "Minimum Requirements for a Comprehensive Managed Fall Protection Program." The ANSI fall protection standard Z359.2-2017 clearly defines all the duties and responsibilities that OSHA will require from an organization using fall protection. Furthermore, ANSI Z359.2 clearly defines issues that are generally not fully defined within OSHA law, such as hazard analysis, rescue plans, and anchorage requirements for fall restraint systems and work positioning systems.

Systems thought to originally be OSHA compliant may not be, specifically if the OSHA inspector uses the "General Duty Clause" to cite the more detailed ANSI Z359.2 Code.

A great starting reference for fall protection is the definitions section of Z359, available for free at [ASSP.org](http://ASSP.org) (search for "Z359.0").

### General Industry—Fall Protection Codes

Fall protection is required starting at four feet for general industry. The most important standard for the safety of your general industry employees is ANSI Z359.2; the most important standard for federal law compliance is OSHA 1910.66 App C.

- ANSI Fall Protection Code Z359 (Nationally Recognized Safety Standard) is available for a nominal fee: search at [ANSI.org](http://ANSI.org).
- OSHA Fall Protection Code 1910.66 App C (Federal Law) is available for free at [OSHA.gov](http://OSHA.gov).

### Construction Industry—Fall Protection Codes

Fall protection is required at six feet for the construction industry. The most important standard for the safety of your construction employees is ANSI Z359.2; the most important standard from a federal law compliance perspective is OSHA 1926. The construction industry-specific fall protection code is ANSI A10.32.

- ANSI Z359 Fall Protection Code (Nationally Recognized Safety Standard)
- ANSI A10.32 Construction Fall Protection. Both ANSI standards are available for a nominal fee: search at [ANSI.org](http://ANSI.org).
- OSHA 1926 Subpart M App C (Federal Law), available for free: search at [OSHA.gov](http://OSHA.gov).



